

# CUH

## Variable Frequency Intelligent Controller for Vibratory Feeder



**SDVC34-Series**  
Instruction Book



## **Preface**

We appreciate your choosing **CUH** brand Vibratory Feeder Controller.

This instruction book includes detailed steps and explanations of installing, parameter setting, mode setting and trouble shooting of the controller. Please read this instruction book carefully before operating the controller and keep it properly.

## Notice

- Never hot plug power cables nor touch the power sockets and connector of the controller in any case to avoid electrical shock or other accidents.
- Never connect the controller to 380V AC power which may cause unrecoverable damage. Choose products that are designed for 380V AC instead when needed.
- Never switch the input power of the controller simply by cutting off power supply through a relay, a PLC or other devices, service life of the controller will be reduced severely. Output of the controller can also be turned on/off via C Ports or E Ports.
- Never operate the controller under the conditions that beyond its designed limits.
- Operate the controller in accordance with this instruction book strictly. We will not assume any civil or criminal liability if the equipment damage or personal injury is caused by incorrect operation.



Never open the controller shell to avoid electric shock. Contact CUH if the controller breaks down.  
Never try to repair the controller yourself which may void the warranty.

# Operating Environment

## Operating Environment

Please follow the instructions below to ensure better performance and longer lifetime of the controller

- ➔ Well-ventilated environment
- ➔ Firmly fixed to avoid self vibration
- ➔ Operate within the temperature range of  $-10\text{ }^{\circ}\text{C}$  to  $40\text{ }^{\circ}\text{C}$
- ➔ Keep away from droplets, steam, dust and especially oily dust
- ➔ Keep away from corrosive or flammable gas and liquid
- ➔ Keep away from floating dust and metal particles
- ➔ Keep away from electromagnetic interference

# Contents

<b>Chapter I Features</b> -----	1
<b>Chapter II Installation Guide</b> -----	2
<b>Chapter III Components Descriptions</b> -----	4
3.1 Descriptions of the Indicators-----	4
3.2 Descriptions of the Buttons-----	5
3.3 Descriptions of I/O Interfaces and Accessory-----	5
3.4 Descriptions of Signal Control Ports-----	6
<b>Chapter IV Parameter Adjustment</b> -----	7
4.1 Common Parameters-----	7
4.2 Basic Parameters-----	7
4.3 Advanced Parameters-----	8
4.4 Auto/ Sync Parameters-----	9
<b>Chapter V Operating Mode</b> -----	10
5.1 Manual Mode-----	10
5.1.1 Output Voltage Parameter U Adjustment in Manual Mode-----	11
5.1.2 Output Frequency Parameter E Adjustment in Manual Mode-----	11
5.2 Auto Mode-----	12
5.2.1 Vibration Sensor Installation-----	12
5.2.2 Feed Speed Parameter A Adjustment in Auto Mode -----	13
5.2.3 Auto Frequency Measuring in Auto Mode -----	13
5.2.4 Explanation of Auto/Sync Parameters -----	14
5.3 Semi-Auto Mode-----	16
5.3.1 Vibration Sensor Installation-----	16
5.3.2 Semi-Auto Mode Setup-----	16
5.3.3 Feed Speed Parameter A Adjustment in Semi-Auto Mode-----	16
5.3.4 Output Frequency Parameter E Adjustment in Semi-Auto Mode-----	17
5.4 Sync Mode-----	18
5.4.1 Connection Method of the Sync Signal Wire between Master and Slave Controllers- 19	19
5.4.2 Sync Mode Applications-----	20
5.4.3 Explanation of Some Auto/Sync Parameters-----	24
<b>Chapter VI Signal Control</b> -----	25
6.1 C Ports ON/OFF Control-----	25
6.1.1 Connection Method of Different Kinds of Switch Sensors and PLC to C Ports-----	25
6.1.2 C Ports ON Delay Parameter J and C Ports OFF Delay Parameter L -----	30
6.1.3 C Ports ON/OFF Control Logical Relation Parameter $\Gamma 2$ -----	31

6.2 E Ports ON/OFF Control-----	32
6.2.1 Connection Method of Different Kinds of Switch Sensors and PLC to E Ports-----	32
6.2.2 E Ports ON Delay Parameter J - and E Ports OFF Delay Parameter L- -----	33
6.2.3 E Ports ON/OFF Control Logical Relation Parameter $\Gamma 7$ -----	34
6.3 Common Parameters of C Ports and E Ports-----	35
6.3.1 Logical Relation Parameter $\Pi$ of C Ports and E Ports-----	35
6.3.2 Switch Sensor Type Parameter $\Gamma A$ -----	36
6.3.3 Whether or not output of the controller is controlled by ON/OFF Control Signal Parameter $\Gamma 4$ -----	36
6.4 Remote Speed Control-----	37
6.5 Storage and Output of Preset Speeds -----	39
6.6 RS485 Communication-----	40
6.6.1 RS485 Communication Address Parameter $\Gamma 1$ -----	40
6.6.2 RS485 Communication Baud Rate Parameter $\Gamma 2$ -----	40
6.6.3 RS485 Communication Protocol-----	40
6.7 24V DC Control Output-----	41
6.7.1 Connection Method of the 24V DC Control Output-----	41
6.7.2 Logical Relation of the 24V DC Control Output -----	42
<b>Chapter VII Security Functions</b> -----	<b>43</b>
7.1 Automatic Voltage Regulation: -----	43
7.2 Short-Circuit Protection-----	43
7.3 Overcurrent Protection-----	43
7.4 Overheat Protection-----	43
7.5 Overload Protection-----	43
7.6 Overvoltage Protection-----	43
<b>Appendix</b> -----	<b>44</b>
<b>Appendix A: Dimensions</b> -----	<b>44</b>
<b>Appendix B: Electrical Specification</b> -----	<b>47</b>
<b>Appendix C: Troubleshooting Suggestions and Error Explanations Explanations</b> Explanations-----	<b>48</b>

# Chapter I Features

The controller is specially designed for controlling vibratory feeder in automation systems. Combined with the latest electronic technologies and elaborate design, the controller has the following convenient and practical features:

**Auto FM:** Automatic output frequency modulation in real time to ensure the vibratory feeder will always work at its best vibration frequency.

**Auto Constant Speed Control:** Automatic output voltage adjustment in real time to ensure constant preset feed speed regardless of weight change of the feed material in the vibratory feeder.

**Auto Frequency Measuring:** Automatically measure and output the best vibration frequency of the vibratory feeder.

**Automatic Voltage Regulation:** Eliminate both feed speed variation caused by mains voltage fluctuation and beat effect caused by industrial AC frequency.

**Waveform Sync:** Sync output waveform of the slave controllers with that of the master controller to the same frequency and phase to avoid beat effect.

**Remote ON/OFF Control:** The controller has 2 groups of ON/OFF control ports. Switch sensor or PLC can be connected to them to turn on/off the controller. Soft Startup Time, ON Delay, Off Delay and Logical Relation of the ON/OFF Control can also be set.

**Automatic Switch Sensor Type Recognition:** The controller can recognize and adapt to both NPN and PNP type switch sensors.

**Soft Startup:** In order to avoid sudden shock to the feed material and vibratory feeder, the controller can gently increase output voltage/feed speed from 0 to the preset value when startup.

**Preset Speeds:** 4 preset feed speeds can be stored and output by external short-circuit signal.

**Acceleration:** Maximum output voltage value of the controller can be increased up to 150% of the input voltage value.

**Max Adjustable Output Voltage:** Max Adjustable Output Voltage can be preset to protect the vibratory feeder from damage caused by high voltage.

**Waveform Index:** Users can balance efficiency and maximum power by adjusting this parameter.

**Remote Speed Control:** Output Voltage/Feed Speed of the controller can be adjusted remotely by an external potentiometer, a PLC, or a 1-5V/4-20mA DC signal.

**24V DC Control Output:** The controller can output 24V DC power associated with logical relation setting of the ON/OFF Control to drive a solenoid, an electrical relay or other external devices.

**Control Panel Lock:** Lock all buttons on the control panel by pressing the ON/OFF button and hold for 2 seconds to prevent misoperation.

**Parameter Lock:** Lock all parameters except Output Voltage/Feed Speed by self defined password to prevent unauthorized operation.

**Controller Reset:** Reset all parameters of the controller to factory defaults.

**RS485 Communication:** All parameters of the controller can be adjusted via RS485 communication ports.



## Chapter II Installation Guide

### Step One:

Open the packing box and check the controller and all accessories.

### Step Two:

Connect the wiring terminals of the Output Power Cable to the vibrator's electromagnetic coil.

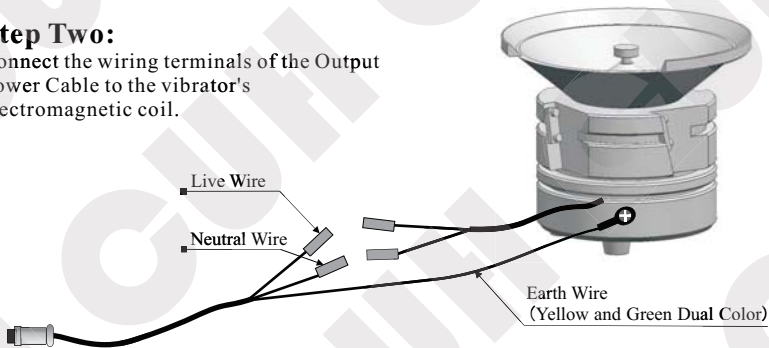

### Notice

Make sure the vibrator's electromagnetic coils is connected to the live wire and neutral wire of the Output Power Cable and the electromagnetic coils is reliably earthed, otherwise serious accident may occur.

### Step Three:

Connect the connector of the Output Power Cable to the Output Power Socket of the controller.



### Step Four:

Connect the connector of the Input Power Cable to the Input Power Socket of the controller.

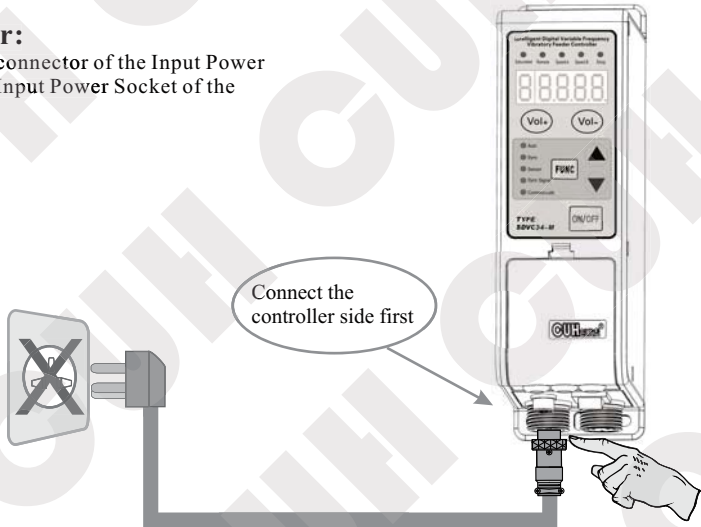

### Step Five:

Connect the plug of the Input Power Cable to the mains jack.

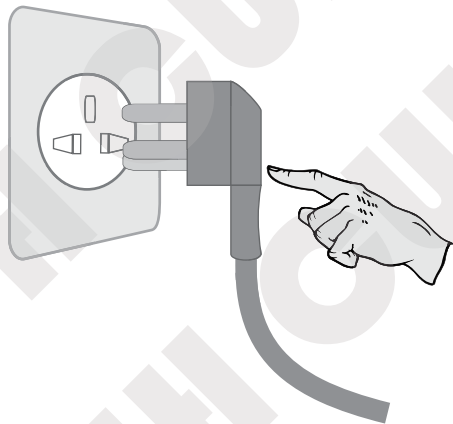

# Chapter III Components Descriptions

## 3.1 Descriptions of the Indicators

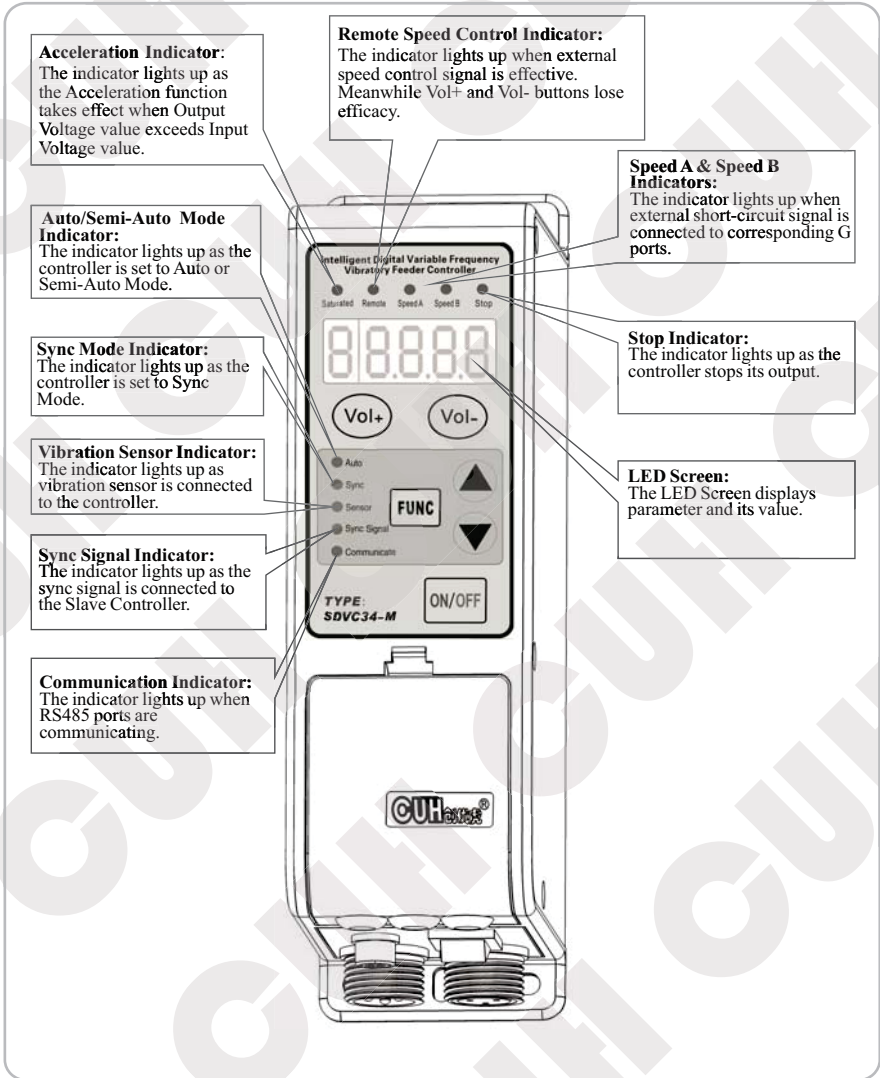

## 3.2 Descriptions of the Buttons

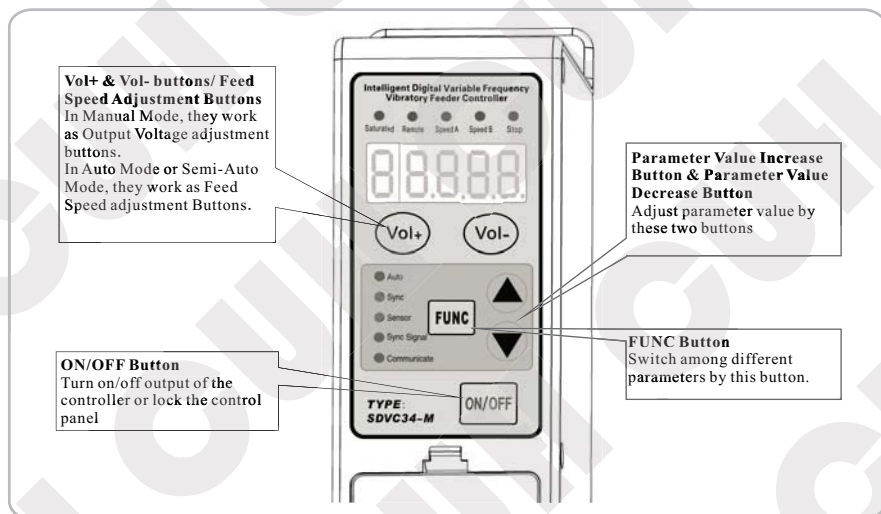

## 3.3 Descriptions of I/O Interfaces and Accessory

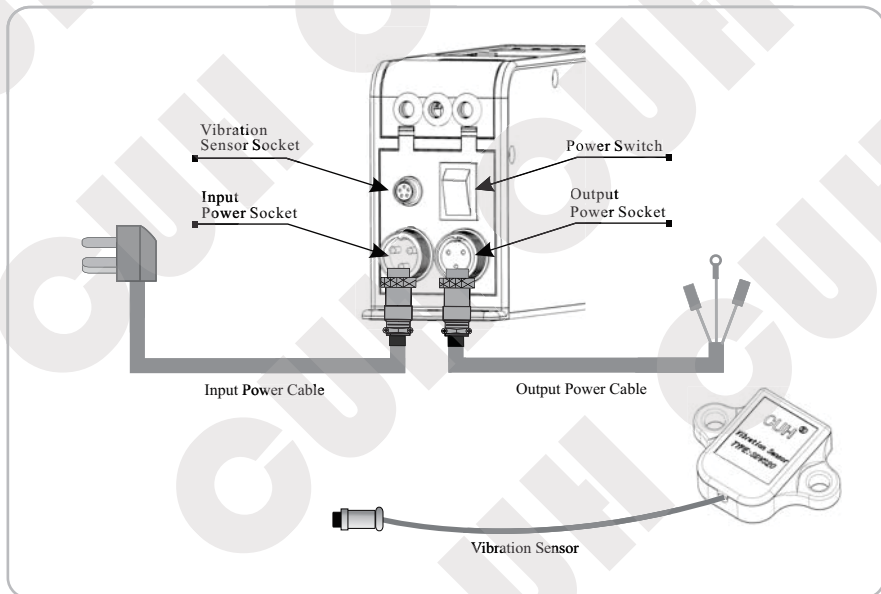

### 3.4 Descriptions of Signal Control Ports

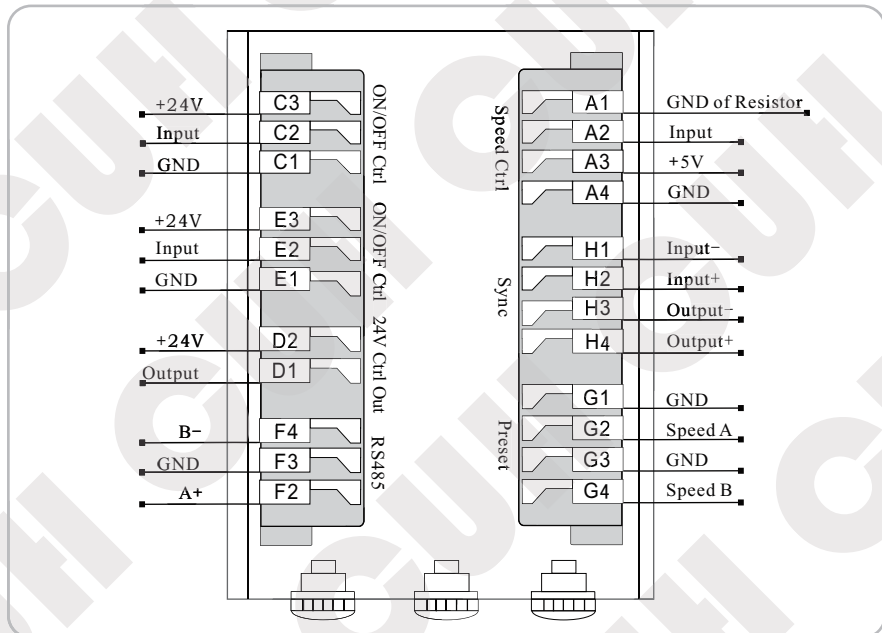

## Chapter IV Parameter Adjustment

Parameters of the controller are classified into 4 types according to different adjustment methods: Common Parameters, Basic Parameters, Advanced Parameters and Auto/Sync Parameters.

### 4.1 Common Parameters

- Press "Vol+" or "Vol-" button to adjust Common Parameters.
- The "Vol+" and "Vol-" buttons are designed to adjust Common Parameters only.
- Common Parameters can be adjusted by pressing "Vol+" or "Vol-" button even when any other parameter is displayed on the LED screen. The controller will go back to the previous parameter after Common Parameter adjustment.

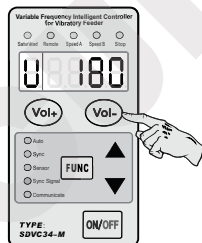

Common Parameter	Symbol	Range	Unit
Output Voltage	U	0~260V	V
Feed Speed	R	0~3200	1

### 4.2 Basic Parameters

- Press "FUNC" button and hold for 2 seconds to enter Basics Parameter Adjustment Status.
- Press "FUNC" button repeatedly to switch cyclically among different parameters.
- Press ▲ or ▼ button to adjust the parameter value.
- Press "FUNC" button again and hold for 2 seconds to exit Basic Parameter Adjustment Status.

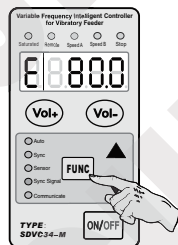

Basic Parameter	Symbol	Range	Unit
Output Frequency	E	25.0~400.0Hz	Hz
Soft Startup Time	T	0.0~10.0s	s
C Ports On Delay	J	0.0~ 2 0.0s	s
C Ports Off Delay	L	0.0~ 2 0.0s	s

### 4.3 Advanced Parameters

- Press "FUNC" and ▲ buttons simultaneously and hold for 2 seconds to enter Advanced Parameter Adjustment Status
- Press "FUNC" button repeatedly to switch cyclically among different parameters.
- Press ▲ or ▼ button to adjust the parameter value
- Press "FUNC" and ▲ buttons simultaneously again and hold for 2 seconds to exit Advanced Parameter Adjustment Status.

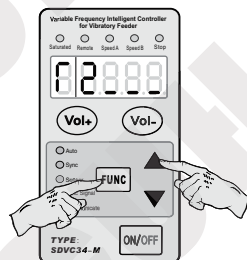

Advanced Parameter	Symbol	Range	Unit
E Ports On Delay	J-	0.0s~20.0s	s
E Ports Off Delay	L-	0.0s~20.0s	s
C Ports Logical Relation	r2	---Positive Logic __ Negative Logic	\
E Ports Logical Relation	r7	---Positive Logic __ Negative Logic	\
24V Ctrl Out Logical Relation	r3	---Positive Logic __ Negative Logic	\
Whether or not output of the controller is controlled by ON/OFF Control Signal	r4	---Relevant ---Irrelevant	\
Switch Sensor Type	rA	Uto: Auto nPn: NPN type Sensor PnP: PNP type Sensor	\
Logical Relation of C Ports and E Ports	r	== OR, == AND, == XOR	\
Max Adjustable Output Voltage	h	0V~260V	V
Acceleration Index	y	100%~150%	%
Waveform Index	r	0~100	1
Temperature Display	r	-10.0℃~80.0℃	℃
Communication Address	r	1~31	1
Communication Baud Rate	r	3~1152	kbps
Parameter Lock Password	r	0~999	1
Controller Reset	888888	888888 Ready for Reset ----- Reset Completed	\

## 4.4 Auto/ Sync Parameters

- Press "FUNC" and ▼ buttons simultaneously and hold for 2 seconds to enter Auto/ Sync Parameter Adjustment Status
- Press "FUNC" button repeatedly to switch cyclically among different parameters.
- Press ▲ or ▼ button to adjust the parameter value
- Press "FUNC" and ▼ buttons simultaneously again and hold for 2 seconds to exit Auto/ Sync Parameter Adjustment Status.

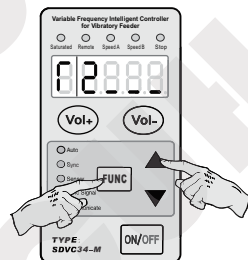

Auto/ Sync Parameter	Symbol	Range	Unit
Centre Frequency	F	25.0Hz~400.0Hz	Hz
Max Offset in Auto FM	n	0.0Hz~180.0Hz	Hz
Output Voltage Adjustment Method	r5	-- Auto -- Manual	\
Output Frequency Adjustment Method	r6	-- Auto -- Manual == Sync	\
Output Frequency Auto Adjustment Index	IF	0~200	1
Amplitude Auto Adjustment Index	PA	0~999	1
Amplitude Auto Adjustment Index	IA	0~999	1
Feed Speed Display	H	0~H	1
Output Voltage Display	C	0~h	V
Max Amplitude Index	P	0~500	1
Max Adjustable Feed Speed	K	0~3200	1
Phase Difference	Y	-180°~180°	1°
Max Output Voltage in Auto Frequency Measuring Process	b	0V~260V	V
Feed Speed Min Adjustment Volume	C	1~10	1
Vibration Sensor Number	t	1~4	1



## Chapter V Operating Mode

The controller can be set to work in one of the following four operating modes according to specific application requirements.

- **Manual Mode:** Both Output Voltage and Output Frequency are manually adjusted
- **Auto Mode:** Both Output Voltage and Output Frequency are auto adjusted based on feedback from the Vibration Sensor to ensure constant preset feed speed and best vibration frequency of the vibratory feeder
- **Semi-Auto Mode:** Output Voltage is auto adjusted based on feedback from the Vibration Sensor to ensure constant preset feed speed. Output Frequency is manually adjusted.
- **Sync Mode:** In Sync Configuration, if Output Frequency of Controller B is always consistent with that of Controller A. We define Controller A as Master Controller, Controller B as Slave Controller and Operating Mode of Controller B as Sync Mode.

Operating Mode	Output Voltage U		Output Frequency E	
	Adjustment Method	$\Gamma$ 5 Setting	Adjustment Method	$\Gamma$ 6 Setting
Manual Mode	Manual	--	Manual	--
Auto Mode	Auto	---	Auto	---
Semi-Auto Mode	Auto	---	Manual	--
Sync Mode	Manual or Auto	-- or ---	Auto Sync with Master Controller	---

### 5.1 Manual Mode

In Manual Mode, both Output Voltage and Output Frequency are manually adjusted.

Operating Mode	Output Voltage U		Output Frequency E	
	Adjustment Method	$\Gamma$ 5 Setting	Adjustment Method	$\Gamma$ 6 Setting
Manual Mode	Manual	--	Manual	--

To simplify operation, Parameter  $\Gamma$ 5 and  $\Gamma$ 6 are set to -- by factory default. Under this setting, the controller will work in Manual Mode if Vibration Sensor is not connected to the controller or work in Auto Mode if Vibration Sensor is connected.

#### Note:

If both  $\Gamma$ 5 and  $\Gamma$ 6 are set to --, the controller will work in Manual Mode whether or not Vibration Sensor is connected to the controller.

If Vibration Sensor is not connected to the controller, the controller will always work in Manual Mode.

### 5.1.1 Output Voltage Parameter U Adjustment in Manual Mode

Actual Output Voltage value of the controller can be displayed on the LED screen digitally and accurately.

- Turn on the power switch when Vibration Sensor is not connected to the controller.
- The LED screen displays Output Voltage Parameter U and its value.
- Adjust the U value by pressing Vol+ or Vol- button.

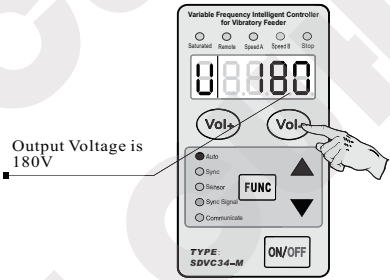

### 5.1.2 Output Frequency Parameter E Adjustment in Manual Mode

With the help of DDS technology, Output Frequency of the controller is always stable and high-precision regardless of time or temperature change.

- Press "FUNC" button and hold for 2 seconds to enter Basic Parameter Adjustment Status.
- The LED screen displays Output Frequency Parameter E and its value.
- Adjust the E Value by pressing ▲ or ▼ button when Vibration Sensor is not connected to the controller.

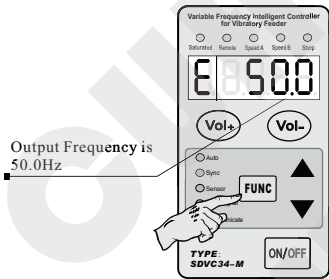

## 5.2 Auto Mode

In Auto Mode, Vibration Sensor must be connected to the controller. Output Voltage and Output Frequency will be adjusted automatically based on feedback from the Vibration Sensor to ensure constant preset feed speed and best vibration frequency. Output Voltage and Output Frequency can not be adjusted manually.

By factory default, when Vibration Sensor is connected, the controller works in Auto Mode.

Operating Mode	Output Voltage U		Output Frequency E	
	Adjustment Method	$\Gamma$ 5 Setting	Adjustment Method	$\Gamma$ 6 Setting
Auto Mode	Auto	---	Auto	---

### Note:

The controller will still work in Manual Mode if Vibration Sensor is not connected.

### 5.2.1 Vibration Sensor Installation

#### Step One:

Connect the connector of the Vibration Sensor to the Vibration Sensor Socket of the controller.

#### Step Two:

Install the vibration sensor head on a secure and even surface of the vibratory feeder firmly.

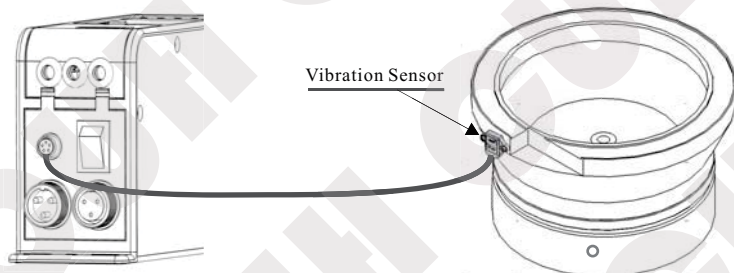

### 5.2.2 Feed Speed Parameter A Adjustment in Auto Mode

- Turn on the power switch when Vibration Sensor is connected to the controller. The Vibration Sensor Indicator lights up.
- The LED screen displays Feed Speed Parameter A and its value.
- Adjust the A Value by pressing "Vol+" or "Vol-" button to desired feed speed.

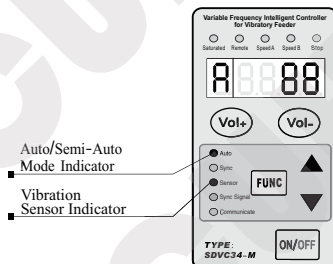

### 5.2.3 Auto Frequency Measuring in Auto Mode

By Auto Frequency Measuring, the controller detects the best vibration frequency of the vibratory feeder and sets all related parameters automatically. The only thing users need to do is to set Feed Speed Parameter A, then the controller will work in the best status.

- Press ▲ and ▼ buttons simultaneously and hold for 3 seconds when Vibration Sensor is connected to the controller to start Auto Frequency Measuring. Output Frequency Parameter E and its value will be displayed on the LED screen in the measuring process.
- After the Auto Frequency Measuring process, the controller will automatically set all related parameters including Centre Frequency parameter F, Max Offset in Auto FM parameter n, Output Frequency Auto Adjustment Index IF, Amplitude Auto Adjustment Index PA, Amplitude Auto Adjustment Index IA, Phase Difference Parameter μ. Output Voltage Adjustment Method Parameter Γ5 and Output Frequency Adjustment Method Parameter Γ6 will be set to \_\_\_.

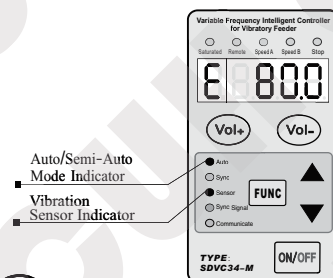

- If the LED Screen displays Err02 the moment Auto Frequency Measuring Process starts, it is normal, because of parameter b is set too high.
- If you want to cancel Auto Frequency Measuring Process, Press ON/OFF button. Then the controller will go back to the status before Auto Frequency Measuring.

After Feed Speed setting and Auto Frequency Measuring, the controller will work in best status at desired feed speed.

## 5.2.4 Explanation of Auto/Sync Parameters

(Concerning adjustment method, value range and unit of Auto/Sync Parameters, please refer to Section 4.4)

### 5.2.4.1 Output Voltage Adjustment Method Parameter $\Gamma 5$

When parameter " $\Gamma 5$ " is set to  $_{-}^{-}$ , Output Voltage parameter U will be visible while parameter A hidden. Output Voltage parameter U can be adjusted manually.

When parameter " $\Gamma 5$ " is set to  $_{-}^{-}$  and Vibration Sensor is connected to the controller, Feed Speed parameter A will be visible while parameter U hidden. Output Voltage will be adjusted automatically based on feedback from the Vibration Sensor to ensure constant preset feed speed.

#### Note:

When Vibration Sensor is not connected to the controller, even if parameter  $\Gamma 5$  is set to  $_{-}^{-}$ , parameter U will still be visible and manually adjustable.

### 5.2.4.2 Output Frequency Adjustment Method Parameter $\Gamma 6$

When parameter " $\Gamma 6$ " is set to  $_{-}^{-}$ , Output Frequency Parameter E can be adjusted manually

When parameter " $\Gamma 6$ " is set to  $_{-}^{-}$  and Vibration Sensor is connected to the controller, Output Frequency Parameter E will be adjusted automatically to resonant frequency (best vibration frequency) of the vibratory feeder based on feedback from the Vibration Sensor. Output Frequency can not be adjusted manually.

When parameter " $\Gamma 6$ " is set to  $_{=}^{=}$  and Sync Signal Wire is connected between Master and Slave Controllers. Output Frequency of Slave Controller will always be consistent with that of Master Controller. Output Frequency of the Slave Controller can not be adjusted manually.

#### Note:

When Vibration Sensor is not connected to the controller, even if parameter  $\Gamma 6$  is set to  $_{-}^{-}$ , Output Frequency will still be adjusted manually.

### 5.2.4.3 Centre Frequency Parameter $F$

Centre Frequency should be set around resonant frequency of the vibratory feeder so that the controller can find the best vibration frequency more quickly.

### 5.2.4.4 Max Offset in Auto FM Parameter $n$

Auto FM range is  $(F \pm n)$  Hz.

Suggested n value is around 30.0Hz.

If Parameter n is set too large, the vibratory feeder may work at improper vibration frequency.

If Parameter n is set too small, flexibility of the vibratory feeder may be affected.

### 5.2.4.5 Output Frequency Auto Adjustment Index $IF$

The Auto FM process is running via PID algorithm. " $IF$ " is a frequency integration index.

The larger Parameter " $IF$ " is set, the faster Output Frequency is auto modulated. But too large " $IF$ " value may cause oscillation of the Output Frequency.

#### 5.2.4.6 Amplitude Auto Adjustment Index **PA**

The controller adjusts Output Voltage automatically via PID algorithm. PA is a speed ratio index.

The larger Parameter PA is set, the faster Output Voltage is auto adjusted. But too large PA value may cause oscillation of the Output Voltage.

#### 5.2.4.7 Amplitude Auto Adjustment Index **IA**

The controller adjusts Output Voltage automatically via PID algorithm. IA is a speed integration index.

The larger Parameter IA is set, the faster Output Voltage is auto adjusted. But too large IA value may cause oscillation of the Output Voltage.

#### 5.2.4.8 Feed Speed Display Parameter **H**

Parameter H is designed for displaying Feed Speed and it is nonadjustable.

#### 5.2.4.9 Output Voltage Display Parameter **G**

Parameter G is designed for displaying Output Voltage and it is nonadjustable.

#### 5.2.4.10 Max Amplitude Index **P**

Set index P to restrict max amplitude of the vibratory feeder.

#### 5.2.4.11 Max Adjustable Feed Speed Parameter **H**

Feed Speed Range is 0 to H. Parameter H restricts Maximum Feed Speed to certain value to protect the vibratory feeder from high voltage caused by misoperation.

Remote Speed Control feed speed is also affected by this parameter.

#### 5.2.4.12 Phase Difference Parameter **P**

Adjust Parameter P to change phase of the output wave, default phase difference is 0°

#### 5.2.4.13 Max Output Voltage in Auto Frequency Measuring Process Parameter **b**

Output Voltage won't exceed the Parameter b value in Auto Frequency Measuring Process to protect the vibratory feeder from damage.

#### 5.2.4.14 Feed Speed Min Adjustment Volume Parameter **C**

Parameter c represents adjustment volume of the Feed Speed Parameter A at one press of Vol+ or Vol- button. Parameter c ranges from 1 to 10.

#### 5.2.4.15 Vibration Sensor Number Parameter **t**

The controller is adaptive to 4 different model Vibration Sensors. Set parameter t according to the sensor model so that when Feed Speed is set, the controller will output the same voltage value no matter which model Vibration Sensor is connected.

Parameter Value	Model	Specification (Acceleration of x axis/y axis/z axis)
1	SDVS20-1	16g/16g/16g
2	SDVS20-2	35g/35g/-
3	SDVS20-3	50g/50g/-
4	SDVS20-4	70g/35g/-

### 5.3 Semi-Auto Mode

In Semi-Auto Mode, Vibration Sensor must be connected to the controller and Parameter  $\Gamma 6$  must be set to  $\_ \_ \_$ .

Output Voltage will be adjusted automatically based on feedback from the Vibration Sensor to ensure constant preset feed speed. Output Frequency will be adjusted manually.

Operating Mode	Output Voltage U		Output Frequency E	
	Adjustment Method	$\Gamma 5$ Setting	Adjustment Method	$\Gamma 6$ Setting
Semi-Auto Mode	Auto	$\_ \_ \_$	Manual	$\_ \_$

**Note:**

The controller will still work in Manual Mode if Vibration Sensor is not connected.

#### 5.3.1 Vibration Sensor Installation

The same with Section 5.2.1

#### 5.3.2 Semi Auto Mode Setup

- Turn on the power switch when Vibration Sensor is connected to the controller. The Vibration Sensor Indicator lights up.
- Press "FUNC" and  $\blacktriangledown$  buttons simultaneously and hold for 2 seconds to enter Auto/Sync Parameter Adjustment Status
- Press "FUNC" button 3 times to switch to Output Frequency Adjustment Method Parameter  $\Gamma 6$
- Press  $\blacktriangle$  or  $\blacktriangledown$  button to set  $\Gamma 6$  to  $\_ \_ \_$ .

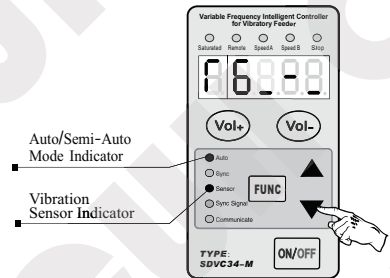

#### 5.3.3 Feed Speed Parameter A Adjustment in Semi-Auto Mode

- Adjust the A Value by pressing "Vol+" or "Vol-" button to desired feed speed.

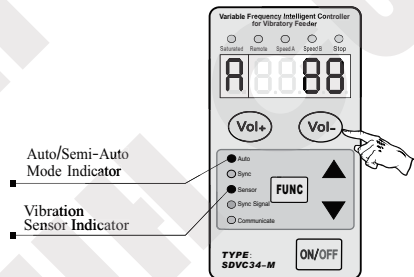

### 5.3.4 Output Frequency Parameter E Adjustment in Semi-Auto Mode

- Press "FUNC" button and hold for 2 seconds to enter Basic Parameter Adjustment Status.
- The LED screen displays Output Frequency Parameter E and its value.
- Adjust the E Value by pressing ▲ or ▼ button.

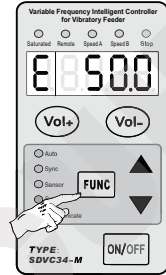



### 5.4 Sync Mode

In Sync Mode, sync signal wire must be connected between the Master and Slave Controllers. Output Frequency of the controller (Slave Controller) is always consistent with that of Master Controller. Output Voltage of the controller (Slave Controller) can be adjusted manually or automatically.

Operating Mode	Output Voltage U		Output Frequency E	
	Adjustment Method	Γ 5 Setting	Adjustment Method	Γ 6 Setting
Sync Mode	Manual or Auto	_ _ or _ _ _	Auto Sync with Master Controller	== ==

Sync Mode apply to the situation that there are more than one controller controlling several vibratory feeders in the feed system, output of the controllers are not synchronous so they interfere with each other (Beat Effect). Sync Mode is designed to eliminate Beat Effect as output waveform of Master and Slave Controllers are exactly synchronous.

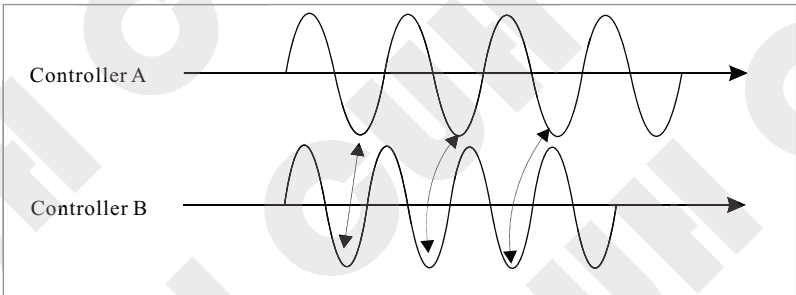

Controller B is not set to Sync Mode, Output Waveforms of the two controllers are not synchronous.

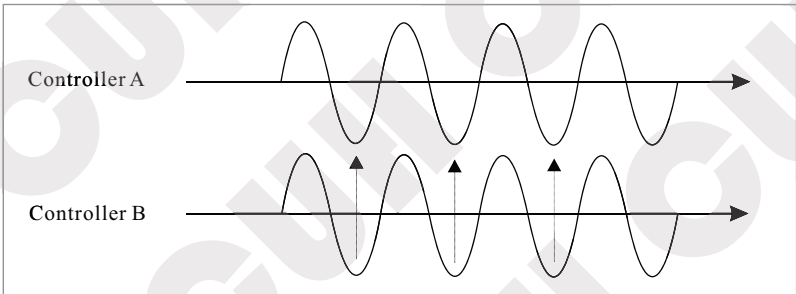

Controller B is set to Sync Mode, Output Waveforms of the two controllers are synchronous.

### 5.4.1 Connection Method of the Sync Signal Wire between Master and Slave Controllers

**Step 1:**

Open the cover plates of the signal control ports boxes of both controllers.

**Step 2:**

Connect the Sync Signal Wire between Master and Slave controllers according to the schematic diagram below.

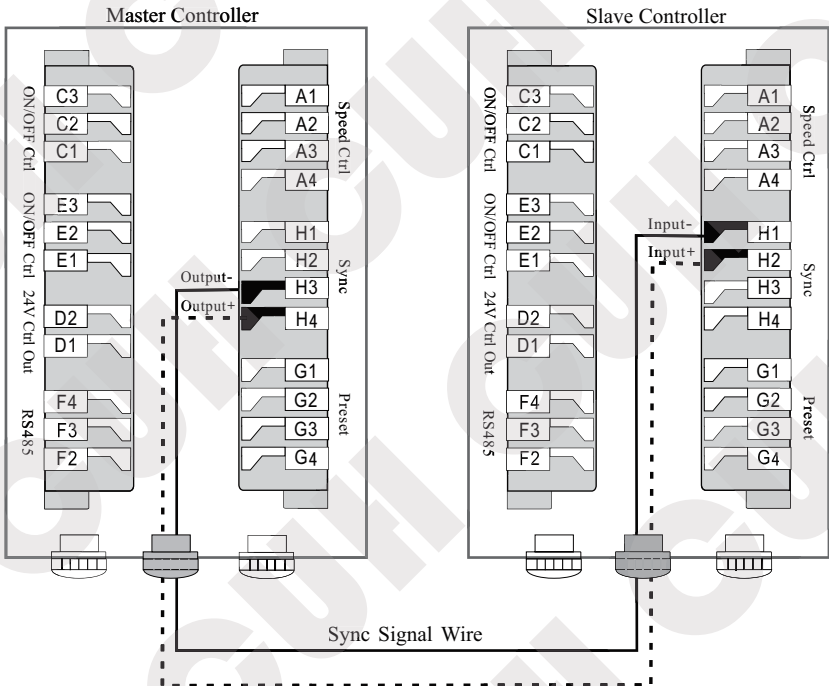
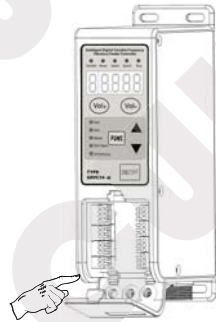

One Master Controller could drive several Slave Controllers.

## 5.4.2 Sync Mode Applications

### Sub-Pattern 1

Controller	Output Voltage U		Output Frequency E	
	Adjustment Method	$\Gamma$ 5 Setting	Adjustment Method	$\Gamma$ 6 Setting
Master Controller	Manual	--	Manual	--
Slave Controller	Manual	--	Auto Sync with Master Controller	-- ==

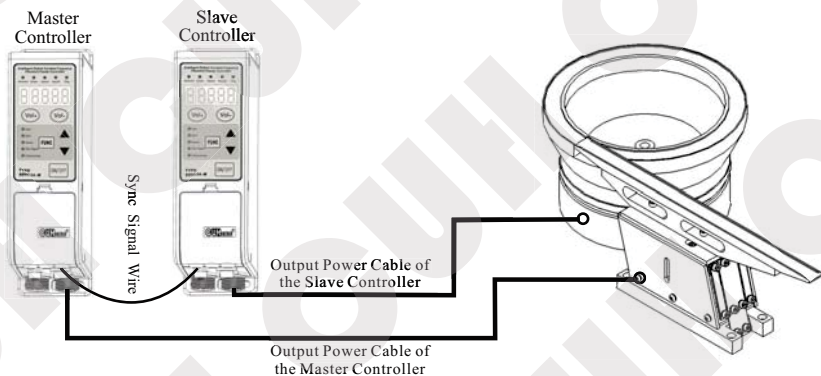

**Sub-Pattern 2**

Controller	Output Voltage U		Output Frequency E	
	Adjustment Method	$\Gamma$ 5 Setting	Adjustment Method	$\Gamma$ 6 Setting
Master Controller	Auto	---	Auto	---
Slave Controller	Manual	- --	Auto Sync with Master Controller	- -- ---

**Sub-Pattern 3**

Controller	Output Voltage U		Output Frequency E	
	Adjustment Method	$\Gamma$ 5 Setting	Adjustment Method	$\Gamma$ 6 Setting
Master Controller	Auto	---	Manual	- --
Slave Controller	Manual	- --	Auto Sync with Master Controller	- -- ---

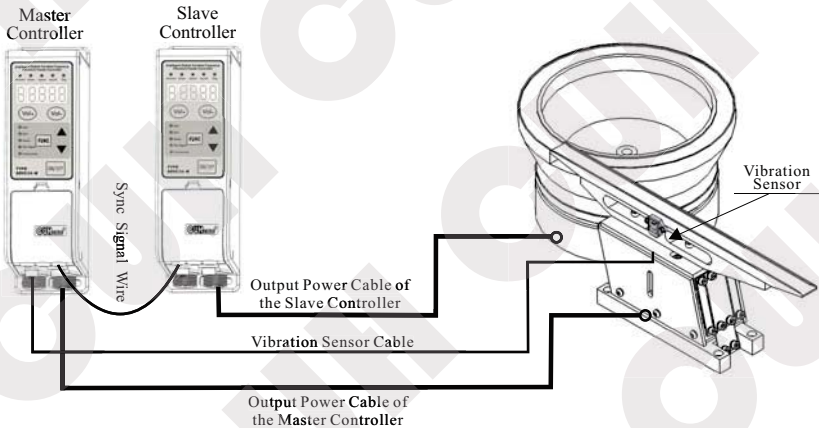

**Sub-Pattern 4**

Controller	Output Voltage U		Output Frequency E	
	Adjustment Method	$\Gamma$ 5 Setting	Adjustment Method	$\Gamma$ 6 Setting
Master Controller	Manual	- --	Manual	- --
Slave Controller	Auto	---	Auto Sync with Master Controller	-- ---

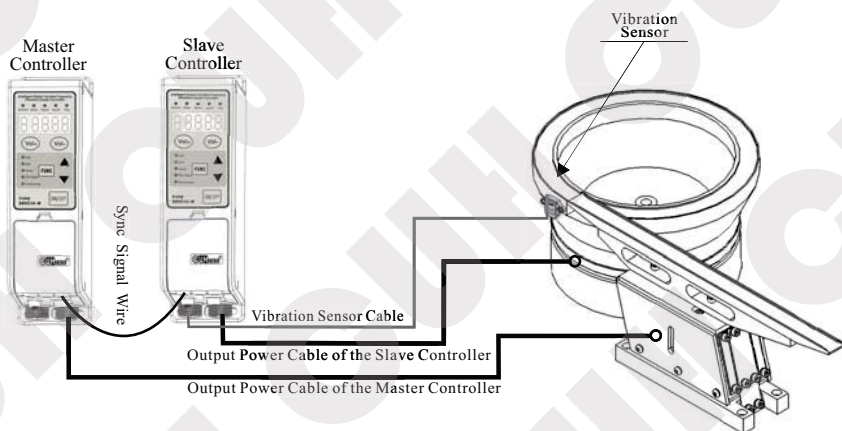

**Sub-Pattern 5**

Controller	Output Voltage U		Output Frequency E	
	Adjustment Method	$\Gamma$ 5 Setting	Adjustment Method	$\Gamma$ 6 Setting
Master Controller	Auto	---	Auto	---
Slave Controller	Auto	---	Auto Sync with Master Controller	---

**Sub-Pattern 6**

Controller	Output Voltage U		Output Frequency E	
	Adjustment Method	$\Gamma$ 5 Setting	Adjustment Method	$\Gamma$ 6 Setting
Master Controller	Auto	---	Manual	--
Slave Controller	Auto	---	Auto Sync with Master Controller	---

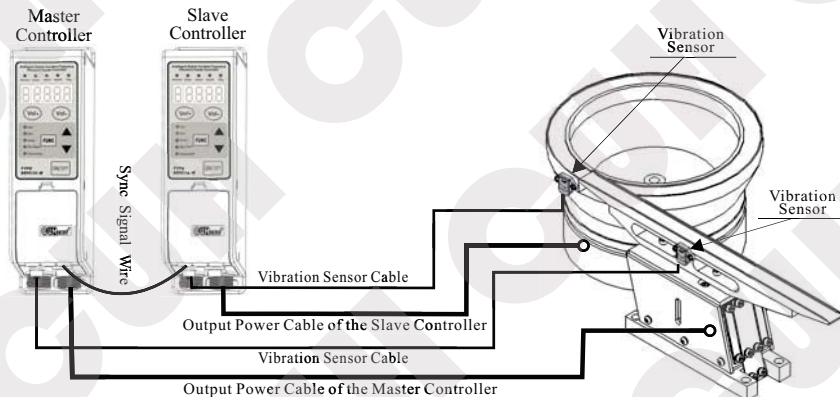

### 5.4.3 Explanation of Some Auto/Sync Parameters

#### 5.4.3.1 Max Adjustable Output Voltage Parameter **h**

Output Voltage Range is 0 to h V. Parameter h restricts Maximum Output Voltage to certain value to protect the vibratory feeder from high voltage caused by misoperation. Remote Speed Control voltage is also affected by this parameter.

#### 5.4.3.2 Acceleration Index **y**

Parameter y ranges from 100% to 150%. Input Voltage\*y=Max Output Voltage  
Output Voltage Value can be adjusted higher than Input Voltage Value by setting this parameter. After setting, Max Output Voltage still won't exceed Parameter h value

#### 5.4.3.3 Waveform Index **r**

Users can weight Max Efficiency (Max Power) and Min Noise by adjusting this index.

#### 5.4.3.4 Temperature Display Parameter **t**

Display internal temperature of the controller in real time. Read only.

#### 5.4.3.4 Controller Reset Parameter **88888**

Reset all parameters to factory default by this parameter when necessary.

#### 5.4.3.5 Parameter Lock Password **7**

Lock all parameters except Output Voltage Parameter U/Feed Speed Parameter A by self defined password to prevent unauthorized operation.

## Chapter VI Signal Control

Signal Control includes: C Ports ON/OFF Control, E Ports ON/OFF Control, Remote Speed Control, Storage and Output of Preset Speeds, RS485 Communication and 24V DC Control Output.

### 6.1 C Ports ON/OFF Control

Output of the controller can be turned on or off by any kind of switch sensor or PLC via C Ports.

#### 6.1.1 Connection Method of Different Kinds of Switch Sensors and PLC to C Ports

##### 6.1.1.1 Connection Method of the Proximity Sensor to C Ports

#### Step 1:

Open the cover plate of the signal control ports box of the controller.

#### Step 2:

Connect the proximity sensor to C Ports according to the diagram.

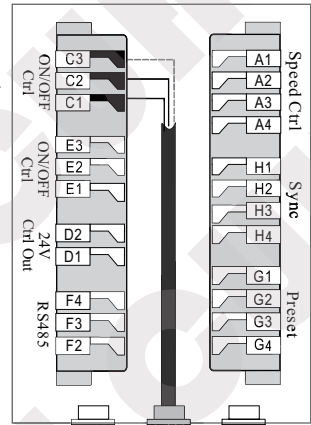
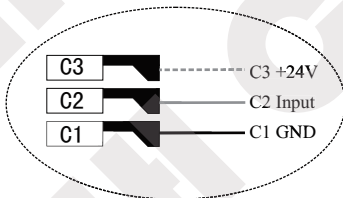
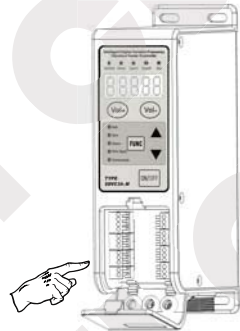

#### Convention

The blue wire represents ground wire  
The black wire represents signal wire  
The brown wire represents power wire

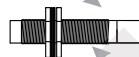

Proximity Switch



**6.1.1.2 Connection Method of the Photoelectric Couple Sensor to C Ports**

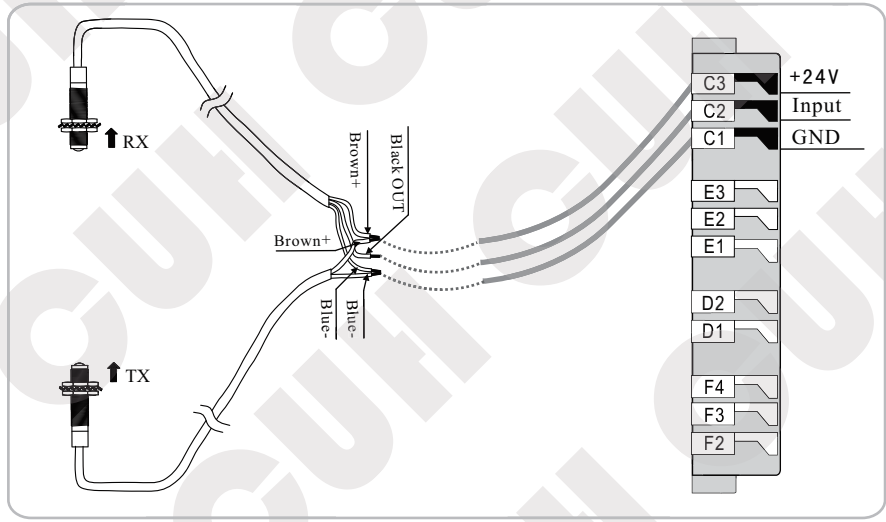
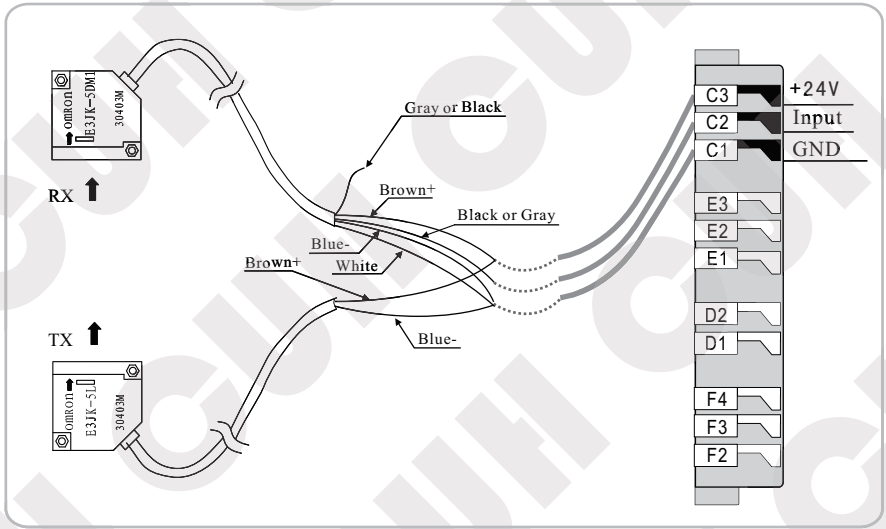

**6.1.1.3 Connection Method of the Photoelectric Reflective Sensor to C Ports**

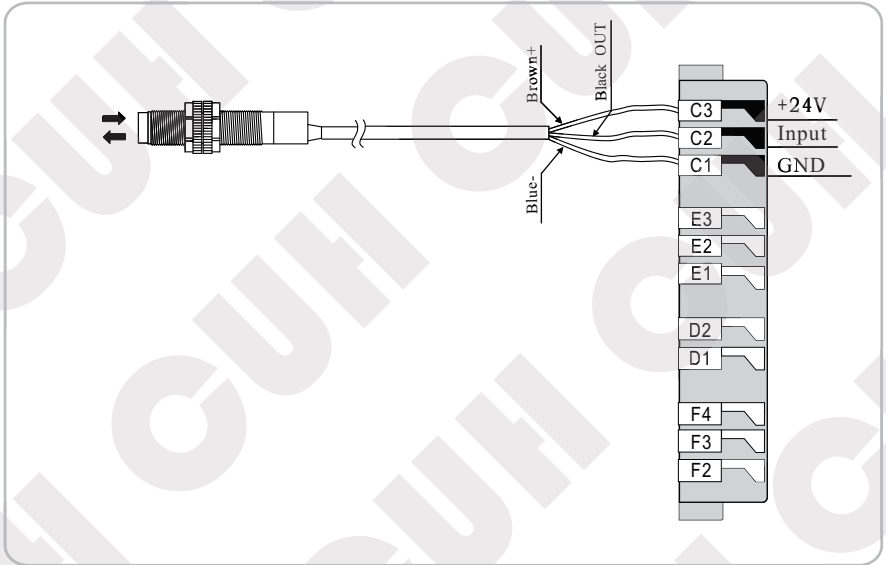

### 6.1.1.4 Connection Method of the Fiber Optic Couple Sensor to C Ports

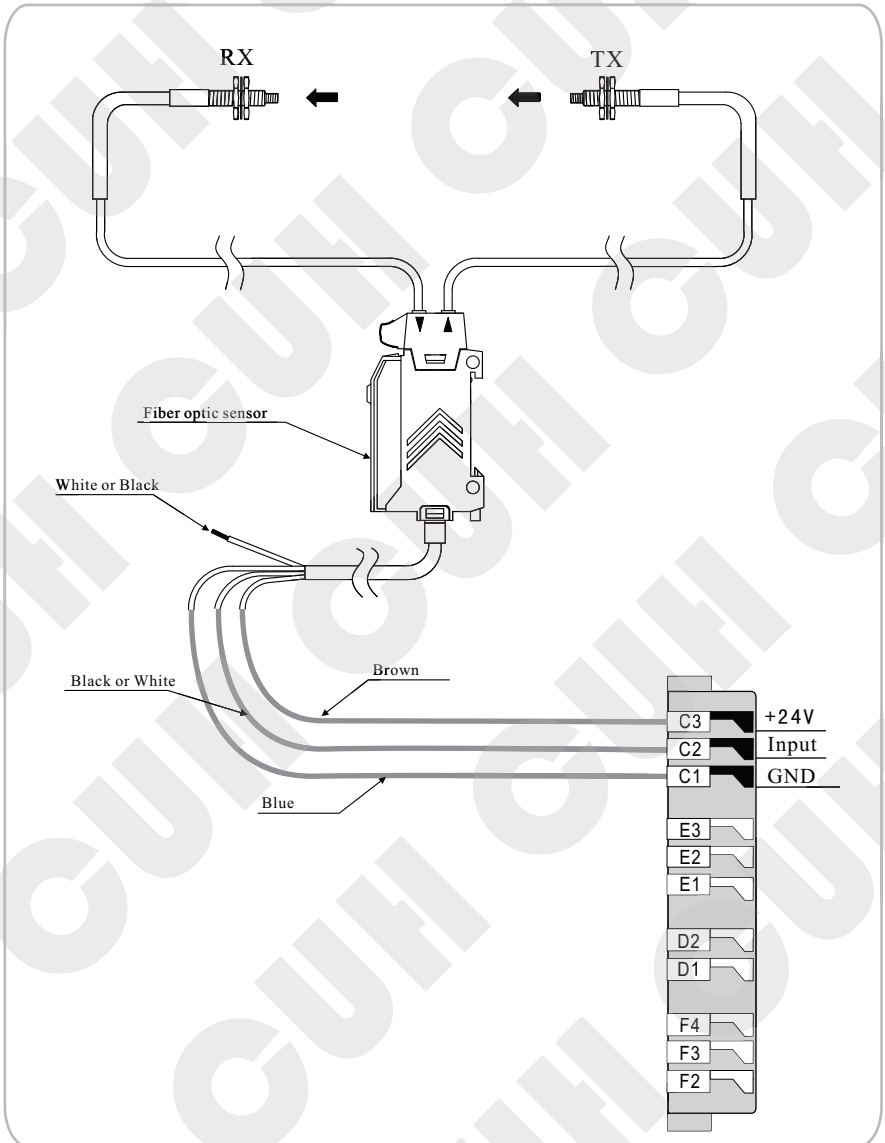

### 6.1.1.5 Connection Method of the PLC to C Ports

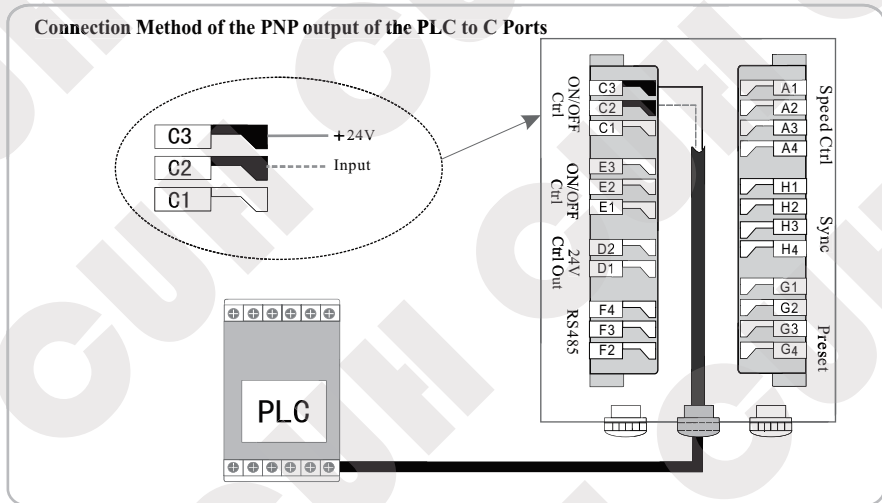
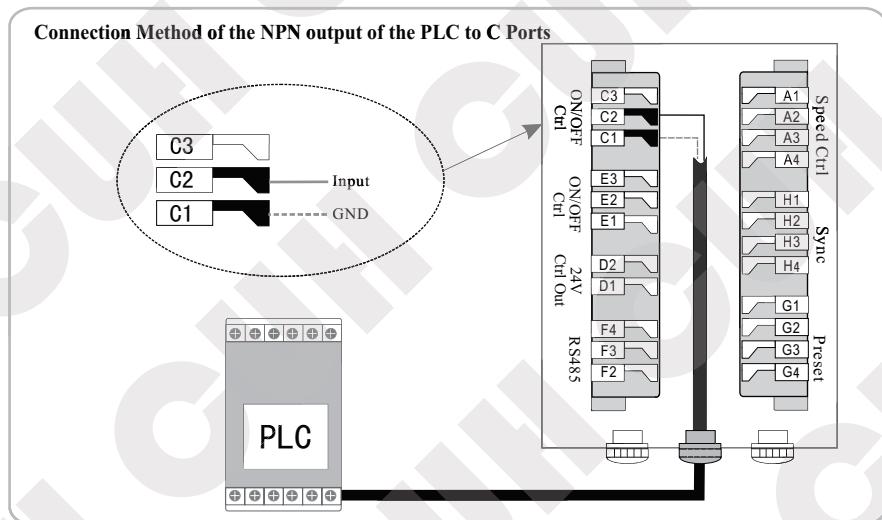

Relay output, NPN output and PNP output of the PLC, any one of them can turn on/off the controller.

## 6.1.2 C Ports ON Delay Parameter J and C Ports OFF Delay Parameter L

If you want the controller to start outputting after a period of time since receiving the C Ports ON Control Signal, adjust Parameter J.

If you want the controller to go on outputting for a period of time after receiving the C Ports OFF Control Signal, adjust Parameter L.

### C Ports ON Delay Parameter J

The period of time from the controller receives the C Ports ON Control Signal to starting output.

- Press "FUNC" button and hold for 2 seconds to enter Basics Parameter Adjustment Status.
- Press "FUNC" button 1 time to switch to Parameter J.
- Press ▲ or ▼ button to adjust the J value. The parameter unit is second, and the adjustment accuracy is 0.1.

ON Delay Time is set as 2 seconds

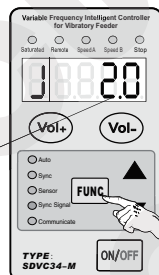

### C Ports OFF Delay Parameter L:

The period of time from the controller receives the C Ports OFF Control Signal to cutting off output.

- Press "FUNC" button and hold for 2 seconds to enter Basics Parameter Adjustment Status.
- Press "FUNC" button 2 times to switch to Parameter L.
- Press ▲ or ▼ button to adjust the L value. The parameter unit is second, and the adjustment accuracy is 0.1.

OFF Delay Time is set as 1.5 seconds

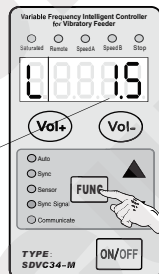

### 6.1.3 C Ports ON/OFF Control Logical Relation Parameter $\Gamma 2$

By factory default, the controller runs when C Ports receives no signal. But in some other applications the controller needs to be stop when C Ports receives no signal.

Adjust Parameter  $\Gamma 2$  to meet either of the requirements.

- Press "FUNC" and ▲ buttons simultaneously and hold for 2 seconds to enter Advanced Parameter Adjustment Status
- Press "FUNC" button 2 times to switch to Parameter  $\Gamma 2$ .
- Press ▲ or ▼ button to change the logical relation.

Parameter  $\Gamma 2$  is set to \_ \_ \_ by default

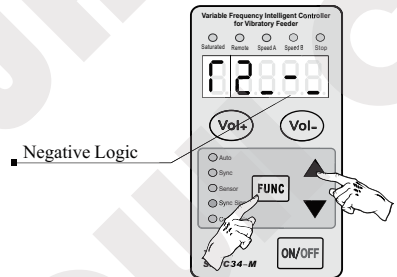
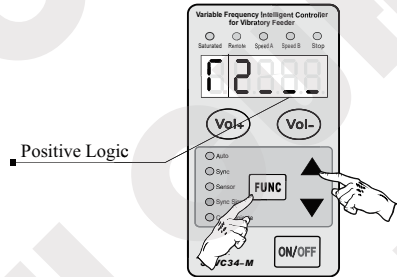

- When Parameter  $\Gamma 2$  is set to \_ \_ \_ , output of the controller will be on when C Ports receives no signal.
- When Parameter  $\Gamma 2$  is set to \_ - \_ , output of the controller will be off when C Ports receives no signal.

## 6.2 E Ports ON/OFF Control

Output of the controller can be turned on or off by any kind of switch sensor or PLC via E Ports C Ports ON/OFF Control and E Ports ON/OFF Control are independent of each other.

### 6.2.1 Connection Method of Different Kinds of Switch Sensors and PLC to E Ports

#### 6.2.1.1 Connection Method of the Proximity Sensor to E Ports

##### Step 1:

Open the cover plate of the signal control ports box of the controller.

##### Step 2:

Connect the proximity sensor to E Ports according to the diagram.

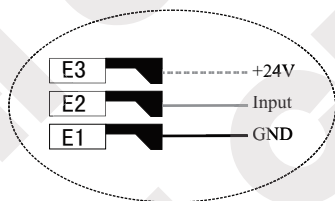
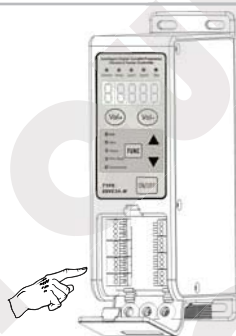

**Convention**  
The blue wire represents ground wire  
The black wire represents signal wire  
The brown wire represents power wire

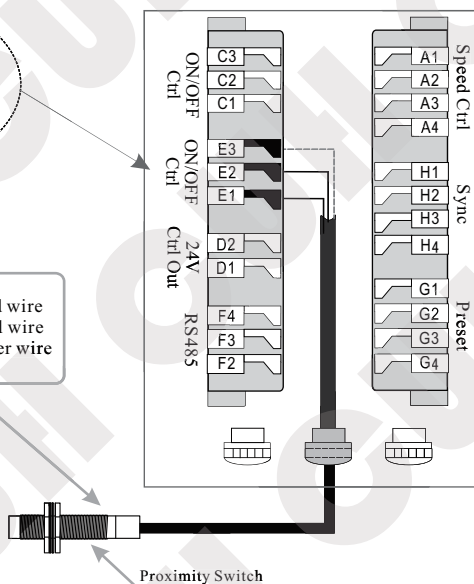

6.2.1.2 Connection Method of other kinds of Switch Sensors and PLC to E Ports are similar to those of C Ports.

### 6.2.2 E Ports ON Delay Parameter J- and E Ports OFF Delay Parameter L-

If you want the controller to start outputting after a period of time since receiving the E Ports ON Control Signal, adjust Parameter J-.

If you want the controller to go on outputting for a period of time after receiving the E Ports OFF Control Signal, adjust Parameter L-.

E Ports ON/OFF Delay is the same with C Ports ON/OFF Delay by factory default.

E Ports ON/OFF Delay can also be set independently by adjusting Parameter J- and Parameter L-.

#### E Ports ON Delay Parameter J-

The period of time from the controller receives the E Ports ON Control Signal to starting output.

- Press "FUNC" and ▲ buttons simultaneously and hold for 2 seconds to enter Advanced Parameter Adjustment Status
- The LED screen displays Parameter J- and its value.
- Press ▲ or ▼ button to adjust the J- value. The parameter unit is second, and the adjustment accuracy is 0.1.

ON Delay Time is set as 2 seconds

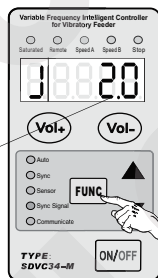

Parameter J- is set to --- by default, meaning the same value with that of Parameter J

#### E Ports OFF Delay Parameter L-

The period of time from the controller receives the E Ports OFF Control Signal to cutting off output.

- Press "FUNC" and ▲ buttons simultaneously and hold for 2 seconds to enter Advanced Parameter Adjustment Status
- Press "FUNC" button 1 time to switch to Parameter L-.
- Press ▲ or ▼ button to adjust the L- value. The parameter unit is second, and the adjustment accuracy is 0.1.

OFF Delay Time is set as 1.5 seconds

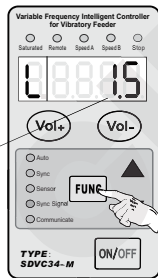

Parameter L- is set as --- by factory default, meaning the same value with that of Parameter L



### 6.2.3 E Ports ON/OFF Control Logical Relation Parameter $\Gamma 7$

By factory default, the controller runs when E Ports receives no signal. But in some other applications the controller needs to be stop when E Ports receives no signal.

Adjust Parameter  $\Gamma 7$  to meet either of the requirements.

- Press "FUNC" and ▲ buttons simultaneously and hold for 2 seconds to enter Advanced Parameter Adjustment Status
- Press "FUNC" button 3 times to switch to Parameter  $\Gamma 7$ .
- Press ▲ or ▼ button to change the logical relation.

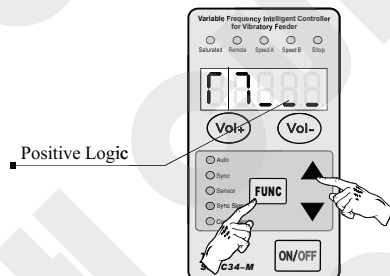

Parameter  $\Gamma 7$  is set to \_\_\_ by default

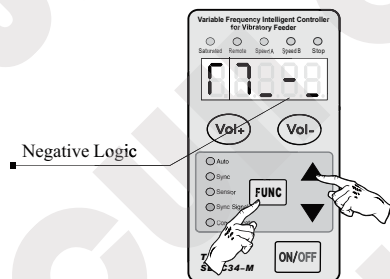

- When Parameter  $\Gamma 7$  is set to \_\_\_\_, output of the controller will be on when E Ports receives no signal.
- When Parameter  $\Gamma 7$  is set to \_\_\_\_, output of the controller will be off when E Ports receives no signal.

## 6.3 Common Parameters of C Ports and E Ports

### 6.3.1 Logical Relation Parameter $\square$ of C Ports and E Ports

Parameter  $\square$  determines the reaction of the controller when both C Ports and E Ports are effective.

- Press "FUNC" and ▲ buttons simultaneously and hold for 2 seconds to enter Advanced Parameter Adjustment Status.
- Press "FUNC" button 8 times to switch to Parameter  $\square$ .
- Press ▲ or ▼ button to change the logical relation.

#### Logical Relation: AND $\square$

Output of the controller will be ON only when both the Ports require the controller to run

#### Logical Relation: OR $\square$

Output of the controller will be ON when either or both of the Ports require the controller to run

#### Logical Relation: XOR $\square$

Output of the controller will be ON only when one of the Ports requires the controller to run and the other requires the controller to stop.

Default Logical Relation is OR.

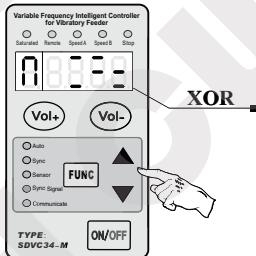
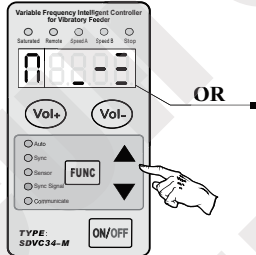
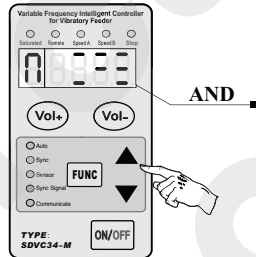
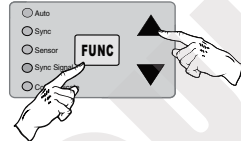

### 6.3.2 Switch Sensor Type Parameter $\Gamma A$

The controller can automatically recognize type of the Switch Sensor, NPN or PNP. Users can also set the Switch Sensor Type manually.

- Press "FUNC" and ▲ buttons simultaneously and hold for 2 seconds to enter Advanced Parameter Adjustment Status.
- Press "FUNC" button 7 times to switch to Parameter  $\Gamma A$ .
- Press ▲ or ▼ button to change the  $\Gamma A$  value.

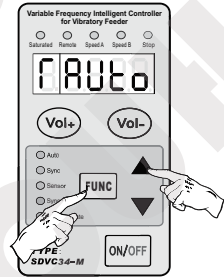

Uto: Switch Sensor Type automatic recognition

nPn: NPN Type Switch Sensor

PnP: PNP Type Switch Sensor

### 6.3.3 Whether or not output of the controller is controlled by ON/OFF Control Signal Parameter $\Gamma 4$

- Press "FUNC" and ▲ buttons simultaneously and hold for 2 seconds to enter Advanced Parameter Adjustment Status.
- Press "FUNC" button 5 times to switch to Parameter  $\Gamma 4$ .
- Press ▲ or ▼ button to change the  $\Gamma 4$  value.

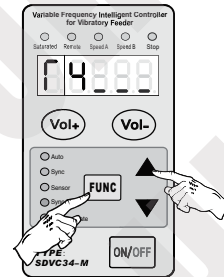

\_\_\_ means correlated

\_\_ \_ means not correlated

Parameter  $\Gamma 4$  is set to \_\_\_ by factory default

## 6.4 Remote Speed Control

Output Voltage/Feed Speed can be controlled by a potentiometer or a 1-5V/4-20mA DC Control Signal remotely.

When Remote Speed Control voltage exceeds 0.5V, it becomes effective to the controller while "Vol<sup>+</sup>" and "Vol<sup>-</sup>" buttons lose efficacy. In the process of Remote Speed Control, the Remote Speed Control Indicator will light up and the LED Screen will display Output Voltage/Feed Speed and its value.

### Connection Method of the Remote Speed Control Potentiometer

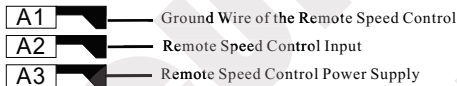

#### Note:

Please select linearity potentiometer with the resistance of 1k.

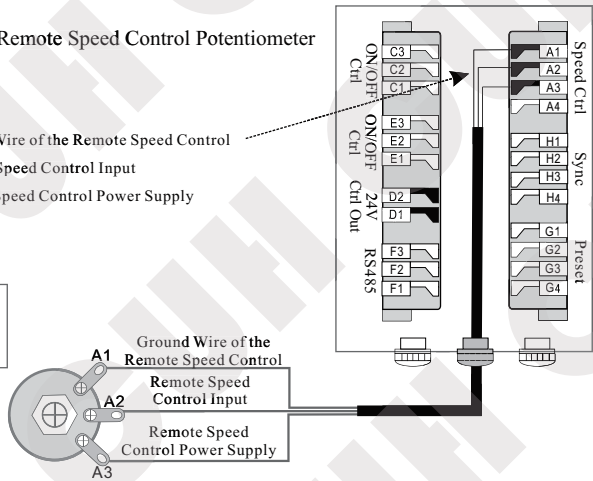

### Connection Method of the Remote Speed Control PLC

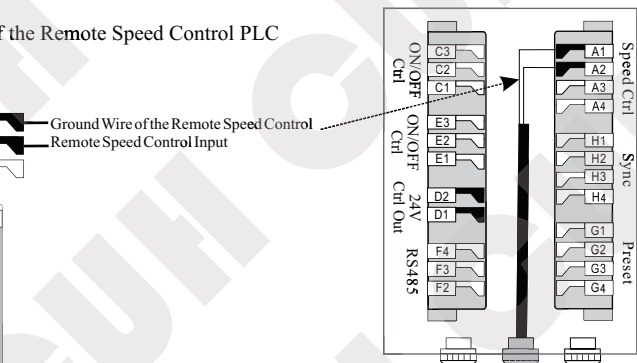

Remote Speed Control Signal	Output Voltage/Feed Speed
less than 0.5V	Controlled by Vol+ and Vol- buttons
0.5V-1V	Output Voltage: 0V/Feed Speed: 0 Controlled by Remote Speed Control Signal
1~5V	Output Voltage/Feed Speed is Linearly Controlled by Remote Speed Control Signal

## 6.5 Storage and Output of Preset Speeds

The controller can store and output 4 different Preset Speeds. The 4 kinds of ON/OFF combination of Speed A Indicator and Speed B Indicator correspond respectively to Speed 1, Speed 2, Speed 3 and Speed 4.

Preset Speed	G1 & G2 Ports		G3 & G4 Ports	
	Speed A Indicator	Switch 1	Speed B Indicator	Switch 2
Speed 1	ON	Closed	OFF	Open
Speed 2	OFF	Open	ON	Closed
Speed 3	ON	Closed	ON	Closed
Speed 4	OFF	Open	OFF	Open

### Connection Method of Preset Speeds

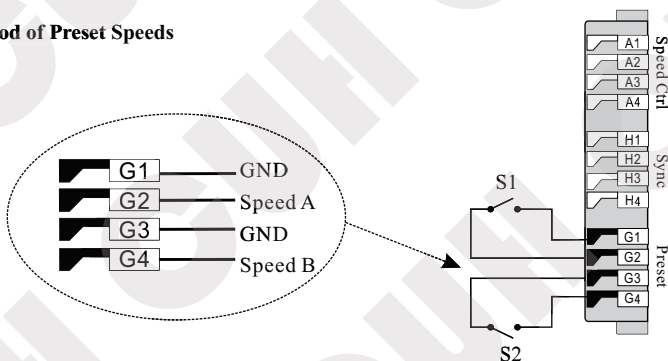

### Storage of Preset Speeds

- Take the storage of Speed 1 for example:
- Close S1, Speed A Indicator lights up, open S2, Speed B Indicator goes off  
To get desired feed speed:  
In Manual Mode, adjust Output Voltage parameter U and Output Frequency parameter E  
In Auto Mode, adjust Feed Speed parameter A  
In Semi-Auto Mode, adjust Feed Speed parameter A and Output Frequency parameter E
- Speed 1 stored automatically

### Output of Preset Speeds

- Take the output of Speed 1 for example:
- Close S1 again, Speed A Indicator lights up, open S2 again, Speed B Indicator goes off  
The controller will output Speed 1 instantly

## 6.6 RS485 Communication

All parameters of the controller can be adjusted remotely via RS485 Communication Ports.

### 6.6.1 RS485 Communication Address Parameter $\uparrow$

Parameter  $\uparrow$  represents ID number of the controller in RS485 communication.

Range of the parameter: 1 to 31

Make sure Communication Address of all controllers in the same network are different to distinguish controllers from each other.

- Press "FUNC" and ▲ buttons simultaneously and hold for 2 seconds to enter Advanced Parameter Adjustment Status
- Press "FUNC" button 13 times to switch to parameter  $\uparrow$
- Press ▲ or ▼ button to change the  $\uparrow$  value.

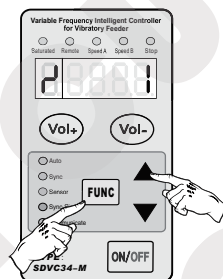

### 6.6.2 RS485 Communication Baud Rate Parameter $\square$

RS485 Communication Baud Rate can be: 3, 12, 24, 96, 192, 576 or 1152.

Unit: 0.1 Kbps

Default Value: 9.6 Kbps

Controllers in the same network should use the same Baud Rate.

- Press "FUNC" and ▲ buttons simultaneously and hold for 2 seconds to enter Advanced Parameter Adjustment Status
- Press "FUNC" button 14 times to switch to parameter  $\square$ .
- Press ▲ or ▼ button to change the  $\square$  value.

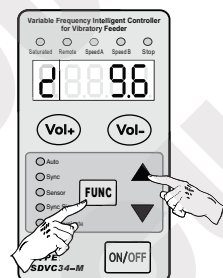

### 6.6.3 RS485 Communication Protocol

RS485 Communication Protocol is available in the Download column of our official website [www.cuh-controller.com](http://www.cuh-controller.com).

## 6.7 24V DC Control Output

The controller can output 24V DC Control power to drive a solenoid valve, an electrical relay or a PLC etc coordinating with C Ports/E Ports ON/OFF Control.

### 6.7.1 Connection Method of the 24V DC Control Output

Connection to a solenoid valve:

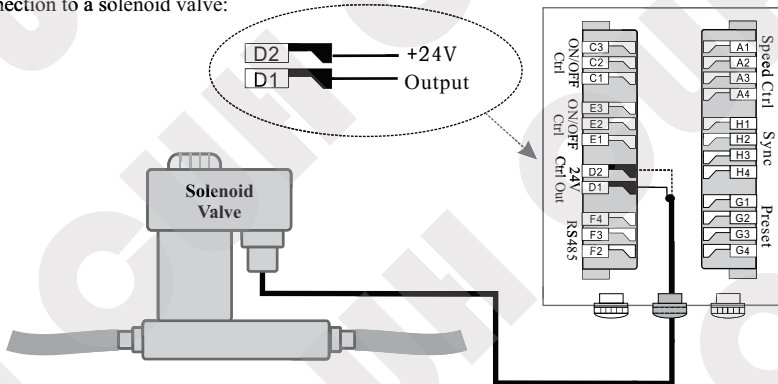

- The controller can drive a solenoid valve which rated voltage is 24V and rated power up to 4W.

Connection to an electrical relay:

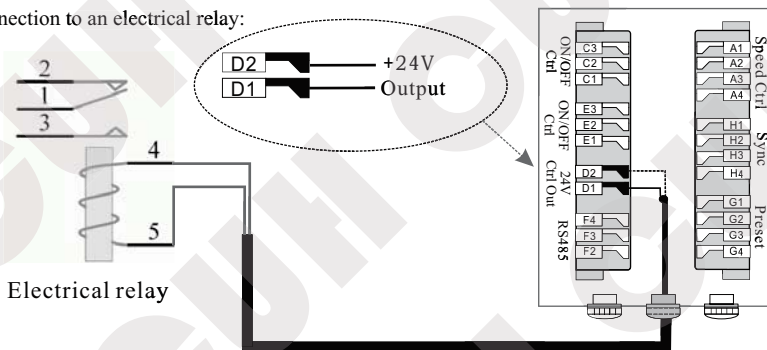

- The controller can drive an electrical relay which rated voltage is 24V and rated power up to 4W.



### 6.7.2 Logical Relation of the 24V DC Control Output

- Press "FUNC" and ▲ buttons simultaneously and hold for 2 seconds to enter Advanced Parameter Adjustment Status
- Press "FUNC" button 4 times to switch to parameter Γ3.
- Press ▲ or ▼ button to change the logical relation.

If Parameter Γ3 is set to \_ \_ \_ , 24V DC Control Output will be on when Output of the controller is on.

If Parameter Γ3 is set to \_ - \_ , 24V DC Control Output will be off when Output of the controller is on.

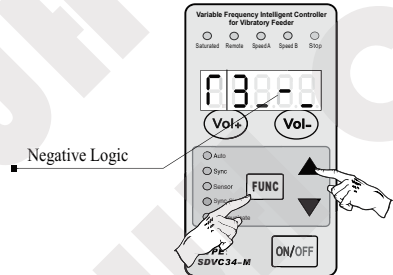
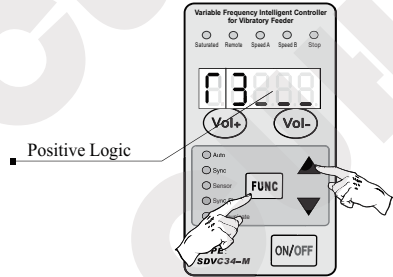

## **Chapter VII Security Functions**

### **7.1 Automatic Voltage Regulation:**

Eliminate both feed speed variation caused by mains voltage fluctuation and beat effect caused by industrial AC frequency.

### **7.2 Short-Circuit Protection**

If output of the controller is short-circuited, the controller will stop its output and display Err01 on the LED screen until restarted.

### **7.3 Overcurrent Protection**

If output current exceeds its rated value by misoperation, the controller will stop its output to ensure operating safety and display Err02 on the LED screen.

### **7.4 Overheat Protection**

If internal temperature of the controller exceeds 65°C, the controller will stop its output to protect itself and display Err02 on the LED screen until internal temperature fall below 60°C.

### **7.5 Overload Protection**

When Vibration Sensor is connected to the controller, if vibration amplitude exceeds Max Amplitude Index setting, the controller will turn down its output to protect the vibratory feeder.

### **7.6 Overvoltage Protection**

If input voltage is much higher than rated input voltage range, fuse inside the controller will be blown to protect the controller from further damage. Please contact us for repair.

# Appendix

## Appendix A: Dimensions

SDVC34-M Unit: mm

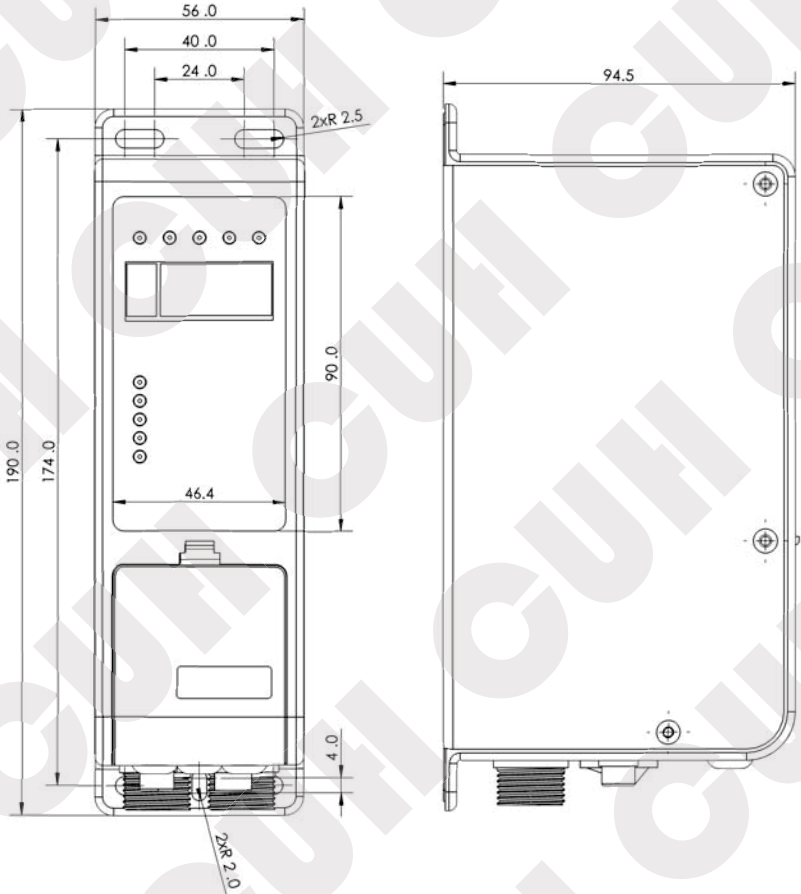

SDVC34-XL Unit: mm

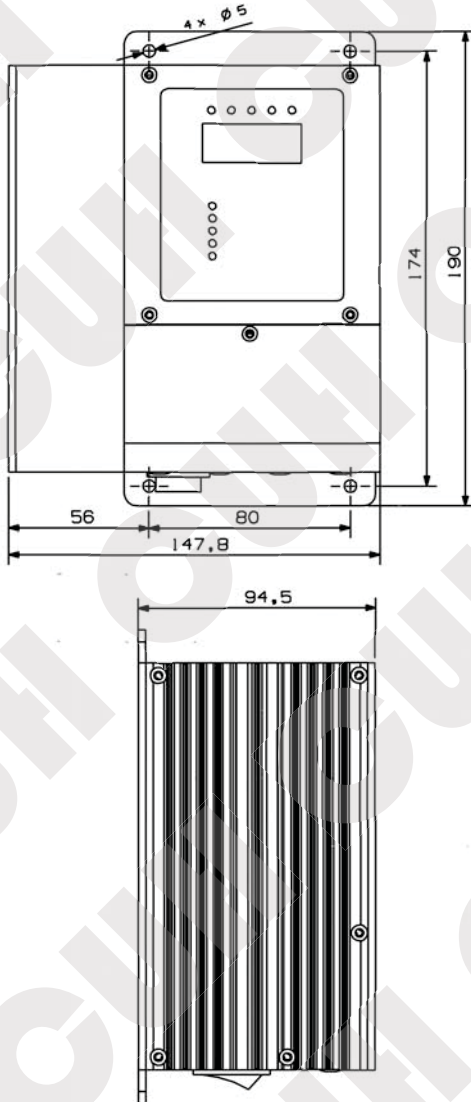



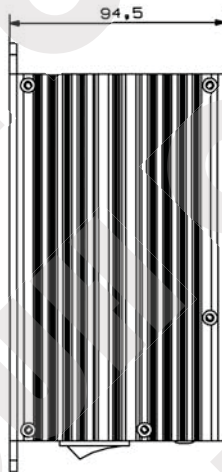
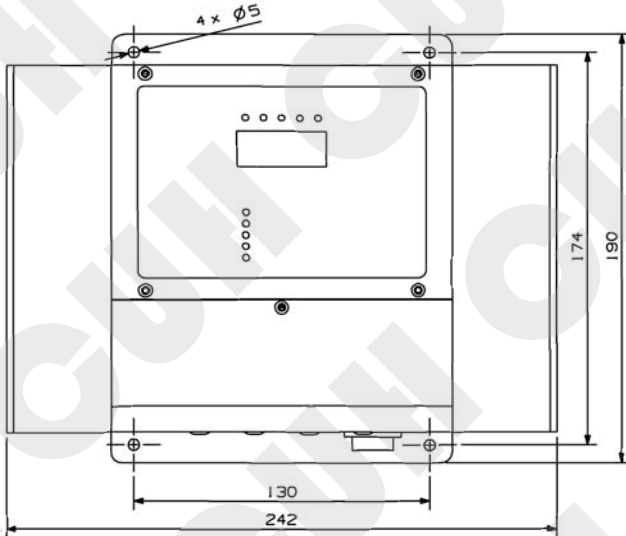

SDVC34-U Unit: mm



## Appendix B:Electrical Specification

Item	Range		Unit	Description
	MIN	MAX		
Output Voltage	0	260	V	
Output Voltage Adjustment Accuracy	1		V	
Output Frequency	25	400	HZ	
Output Frequency Adjustment Accuracy	0. 1		HZ	
Output Waveform	sine			
Output Current		3. 0	A	SDVC34-M
		6. 0		SDVC34-XL
		10. 0		SDVC34-U
Output Power		660	VA	SDVC34-M
		1320		SDVC34-XL
		2200		SDVC34-U
ON/OFF Delay	0	2. 0	S	
ON/OFF Delay Adjustment Accuracy	0. 1		S	
Soft Startup	0	10. 0	S	
DC Control Output Voltage	22	26	V	24V DC Control Power Supply
DC Control Output Current		200	mA	24V DC Control Power Supply
Stand-by Power Consumption	1. 5	3. 0	W	
Display Method		5. 0		LED Digital Tube
Control Method	1. 0	5. 0	V	Analog Signal Input
	0	24	V	Switch Signal Input/Output
	6 Buttons plus LED			Control Panel

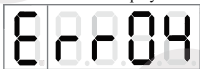
## Appendix C: Troubleshooting Suggestions and Error Explanations Explanations Explanations

	Fault Phenomenon	Troubleshooting Suggestions
1	No display on LED screen after power on startup	<ul style="list-style-type: none"> <li>● Make sure the mains jack is live</li> <li>● Make sure the Input Power Cable is reliably connected</li> </ul>
2	LED screen displays normally but vibratory feeder has no output or sound	<ul style="list-style-type: none"> <li>● Make sure the Output Power Cable is reliably connected</li> <li>● Make sure Output Voltage is not too low</li> <li>● Make sure the controller is not stopped by the ON/OFF button when the Stop Indicator is on</li> <li>● Make sure the controller is not stopped by the ON/OFF control signal when the Stop Indicator is on</li> <li>● Make sure the controller is not stopped by parameters I2 or I7 setting when the Stop Indicator is on</li> <li>● Reset the controller</li> </ul>
3	ON/OFF Control does not work	<ul style="list-style-type: none"> <li>● Make sure ON/OFF Control Signal is correctly connected to the controller</li> <li>● Make sure parameter I2, I7 and I1 are set correctly as you control expectation</li> <li>● Reset the controller</li> </ul>
4	Beat Effect	<ul style="list-style-type: none"> <li>● Connect Sync Signal Wire between the controllers and set the Slave Controller to Sync Mode</li> </ul>
5	LED screen displays normally, sounds can be heard from the vibratory feeder but no output	<ul style="list-style-type: none"> <li>● Make sure Output Frequency is not far away from resonant frequency of the vibratory feeder</li> <li>● Reset the controller</li> </ul>
6	LED screen displays 	Short-Circuit Protection <ul style="list-style-type: none"> <li>● Make sure the Output Power Cable and the vibrator electromagnet are not short circuited</li> <li>● Disconnect the Output Power Cable from the controller and turn on the power switch again. If Err01 is still displayed on the LED screen, contact us for repair</li> </ul>
7	LED screen displays 	Overcurrent Protection <ul style="list-style-type: none"> <li>● Reduce Output Voltage of the controller</li> <li>● Make sure armature gap of the vibrator electromagnet is not too big</li> </ul>
8	LED screen displays 	Overheat Protection <ul style="list-style-type: none"> <li>● Place the controller in a well ventilated environment</li> </ul>
9	LED screen displays 	<ul style="list-style-type: none"> <li>● Reserved, contact us for repair</li> </ul>
10	LED screen displays 	<ul style="list-style-type: none"> <li>● Reserved, contact us for repair</li> </ul>

## **Note:**

### **Controller Reset**

**Step1:** Press "FUNC" and ▲ buttons simultaneously and hold for 2 seconds to enter Advanced Parameter Adjustment Status

**Step2:** Press "FUNC" button 16 times to switch to the 88888 parameter flashing on the LED screen

**Step3:** press ▲ button and hold until ----- is displayed on the LED screen

**Step4:** Release ▲ button to finish the Controller Reset process, U150 is displayed on the LED screen.





